

Experimental Study on the Mechanism of Gas-Phase Aromatic Nitration by Protonated Methyl Nitrate

Massimiliano Aschi, Marina Attinà, Fulvio Cacace,* and Andreina Ricci

Contribution from the University of Rome "La Sapienza", Piazzale Aldo Moro 5, 00185 Rome, Italy

Received February 4, 1994[Ⓞ]

Abstract: The mechanism of gas-phase aromatic substitution by $(\text{CH}_3\text{ONO}_2)\text{H}^+$ ions has been studied by a combination of FT-ICR mass spectrometry and atmospheric pressure radiolytic techniques. Clarifying a long-standing ambiguity, the ICR results characterize the $\text{CH}_3\text{OH}-\text{NO}_2^+$ complex (**1**), in essence a nitronium ion solvated by a methanol molecule, as the nitrating agent, whereas the $\text{CH}_3\text{NO}_2\text{H}^+$ isomer (**2**) is devoid of nitrating properties and reacts with benzene exclusively as a Brønsted acid. Indeed, the reaction with benzene has been exploited as an ICR "titration" technique to evaluate the relative abundances of **1** and **2** in mixed populations of $(\text{CH}_3\text{ONO}_2)\text{H}^+$ ions from different preparative procedures. Radiolytic nitration of *p*-H-toluene-*d*₇ and *p*-D-toluene-*h*₇ leads to intraannular hydron migration from the ipso nitrated position, whose rate has been estimated to be ca. $1.6 \times 10^6 \text{ s}^{-1}$ at 315 K. The mutually supporting evidence from the ICR and the radiolytic experiments outlines a reaction mechanism involving preliminary formation of a Wheland intermediate from the attack of **1** on the arene, followed by its isomerization into the more stable O-protonated nitrobenzene structure via a proton shift whose rate is estimated to be ca. $3.6 \times 10^7 \text{ s}^{-1}$ at 315 K. The results are compared with those of a recent theoretical analysis of the mechanism of aromatic nitration by isomeric $(\text{CH}_3\text{ONO}_2)\text{H}^+$ ions, and their correlation with condensed-phase nitration is briefly discussed.

The mechanism of aromatic nitration continues to be the focus of active interest^{1,2} and the subject of experimental³⁻¹⁴ and theoretical¹⁵⁻¹⁹ research. There is growing interest in gas-phase studies, which are largely unaffected by the complicating effects of a bulk-phase solvating environment and whose results are directly comparable to those of theoretical methods. Among experimental approaches, those based on the joint application of mass spectrometric and radiolytic techniques have allowed aromatic nitration to be investigated in a pressure range up to 760 Torr and above, where it obeys thermal kinetics and its selectivity and orientation are amenable to meaningful comparison with those measured in solution.²⁰

The reagent most widely employed in these studies is protonated methyl nitrate, a NO_2^+ "carrier" whose reactivity in CH_4 at 310

K and 720 Torr conforms to the trends long established in solution and whose partial rate factors fit a Hammett's correlation characterized by a ρ value of -3.87 .⁶ Whereas the electrophilic character of the nitration is firmly established, no definite conclusions could be reached on its detailed mechanism, particularly as it concerns the crucial question related to the intermediacy of a Wheland complex. A major problem is that protonated methyl nitrate is known to exist in two isomeric forms, one corresponding to a $\text{CH}_3\text{OH}-\text{NO}_2^+$ complex and one protonated at the nitro group. The two protomers, discovered and characterized by structurally diagnostic mass spectrometric techniques,²¹ have been the subject of various theoretical studies.

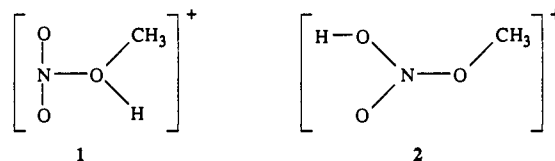

According to an early MINDO study, **1** is more stable than **2** by ca. 20 kcal mol⁻¹,²² whereas *ab initio* calculations at the STO-3G and 4-31G level of theory showed instead that **2** is more stable by 6.7 kcal mol⁻¹.²³ Subsequent calculations at the CISD (ssc)/6-311G** level of theory characterized **1** as more stable than **2** by 4.9 kcal mol⁻¹,²⁴ a result confirmed by a recent study at the CCSD(T) + ZPVE level of theory, whose results show that **1** is more stable than **2** by 4.9 ± 4 kcal mol⁻¹.²⁵

In summary, the available theoretical evidence is hardly conclusive with regard to the role of protomers **1** and **2** in gas-phase aromatic nitration. In fact, whereas the most recent and reliable theoretical studies concur in identifying **1** as the more stable protomer, the small computed stability gap, its relatively large uncertainty, and the high barrier (ca. 60 kcal mol⁻¹) for **1**

- * Abstract published in *Advance ACS Abstracts*, September 1, 1994.
- (1) Schofield, K. *Aromatic Nitration*; Cambridge University Press: Cambridge 1980.
- (2) Olah, G. A.; Malhotra, R.; Narang, S. C. *Nitration Methods and Mechanisms*; VCH: New York, 1989.
- (3) Masnovi, J. M.; Hilinski, E. F.; Rentzepis, P. M.; Kochi, J. K. *J. Am. Chem. Soc.* **1986**, *108*, 1126.
- (4) Ebersson, L.; Radner, F. *Acta Chim. Scand. Sect. B* **1986**, *40*, 71.
- (5) Sankararaman, S.; Haney, W. A.; Kochi, J. K. *J. Am. Chem. Soc.* **1987**, *109*, 5253, 7824.
- (6) Attinà, M.; Cacace, F.; Yañez, M. *J. Am. Chem. Soc.* **1987**, *109*, 5092.
- (7) Attinà, M.; Cacace, F.; de Petris, G. *Angew. Chem., Int. Ed. Engl.* **1987**, *26*, 1177.
- (8) Attinà, M.; Cacace, F.; Ricci, A. *Tetrahedron* **1988**, *44*, 2015.
- (9) Attinà, M.; Cacace, F.; Ricci, A. *Gazz. Chim. Ital.* **1989**, *119*, 217.
- (10) Johnson, J. F.; Ridd, H.; Sandall, J. P. B. *J. Chem. Soc., Chem. Commun.* **1989**, 244.
- (11) Attinà, M.; Cacace, F.; Cipollini, R.; Ricci, A. *Gazz. Chim. Ital.* **1989**, *119*, 217.
- (12) Masci, B. *Tetrahedron* **1989**, *45*, 2719.
- (13) Sankararaman, S.; Kochi, J. K. *J. Chem. Soc., Perkin Trans. 2* **1991**, 1.
- (14) Attinà, M.; Cacace, F.; Speranza, M. *Int. J. Mass Spectrom., Ion Processes* **1992**, *117*, 37.
- (15) Politzer, R.; Jayasuriya, K.; Sjöberg, P.; Laurance, R. *J. Am. Chem. Soc.* **1985**, *107*, 1174.
- (16) Feng, J.; Zheng, X.; Zerner, M. C. *J. Org. Chem.* **1986**, *51*, 4531.
- (17) Glegghorn, J. T.; Torossian, G. *J. Chem. Soc., Perkin Trans. 2* **1987**, 1303.
- (18) Sandall, J. P. B. *J. Chem. Soc., Perkin Trans. 2* **1992**, 1689.
- (19) Szabò, K. J.; Hörnfeld, A. B.; Gronowitz, S. *J. Am. Chem. Soc.* **1992**, *114*, 6827.
- (20) Cacace, F. *Acc. Chem. Res.* **1988**, *21*, 215.

- (21) de Petris, G. *Org. Mass Spectrom.* **1990**, *25*, 83.
- (22) Dewar, M. J. S.; Shanshal, M.; Worley, S. D. *J. Am. Chem. Soc.* **1989**, *91*, 3590.
- (23) Bernardi, F.; Cacace, F.; Grandinetti, F. *J. Chem. Soc., Perkin Trans. 2* **1989**, 413.
- (24) Glaser, R.; Choy, G. S.-C. *J. Org. Chem.* **1992**, *57*, 4976.
- (25) Lee, T. J.; Rice, J. E. *J. Am. Chem. Soc.* **1992**, *114*, 8247.

↔ 2 interconversion²⁴ do not allow to establish with any degree of confidence which isomer is the nitrating reagent. Accordingly, two different mechanisms have been proposed, a "classical" one (I) involving the intermediacy of an arenium ion and a concerted

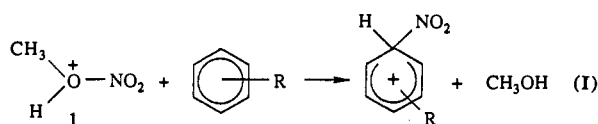

one (II) involving formation of O-protonated nitrobenzenes.

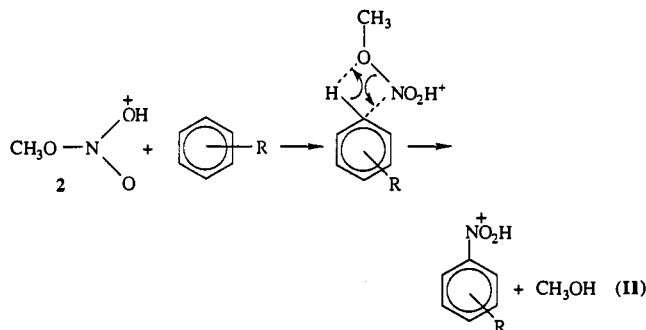

Given the current interest in the study of gas-phase reactions to establish a more direct link between experimental and theory and the conspicuous role of protonated methyl nitrate in the study of gas-phase aromatic nitration, it is of interest to elucidate the above ambiguity and to establish the detailed mechanism of the $(\text{CH}_3\text{ONO}_2)\text{H}^+$ reactions with model arenes.

A theoretical effort in this direction is represented by a recent study of nitration of benzene and toluene by $(\text{CH}_3\text{ONO}_2)\text{H}^+$ isomers 1 and 2, performed at HF/3-21G level, with single-point calculations at the MP4DQ/3-31G level of theory.¹⁹

In this study we address the same problem with a combination of mass spectrometric and radiolytic techniques, using in particular hydron shifts in selectively deuterated arenes as a mechanistic probe to clarify the crucial question concerning the intermediacy of arenium ions.

Results and Discussion

A. ICR Mass Spectrometry. 1. Methods. Unusual difficulties have been encountered in the mass spectrometric study of the reactions of $(\text{CH}_3\text{ONO}_2)\text{H}^+$ ions with arenes, which accounts for the discrepant results of chemical ionization (CI) and ion cyclotron resonance (ICR) studies performed under seemingly similar conditions. A major problem arises from the widely different isomeric compositions of the $(\text{CH}_3\text{ONO}_2)\text{H}^+$ populations from the many preparation methods available, which include (i) addition of NO_2^+ to CH_3OH , (ii) protonation of CH_3ONO_2 with gaseous Brønsted acids, (iii) reaction of $\text{CH}_3\text{ONO}_2^{*+}$ ions with CH_3ONO_2 , (iv) methylation of $\text{C}_2\text{H}_5\text{ONO}_2$ with CH_3F^{*+} , $\text{CH}_3\text{-FH}^+$, and $(\text{CH}_3)_2\text{F}^+$ ions, and (v) NO_2^+ transfer from $\text{CH}_3\text{O}(\text{NO}_2)_2^+$ or $(\text{CH}_3\text{ONO}_2)\text{H}^+$ ions to CH_3OH , etc.¹⁴ Another major problem is that the ions from the above formation processes are known^{14,26} to react with arenes, e.g. benzene, according to competitive processes

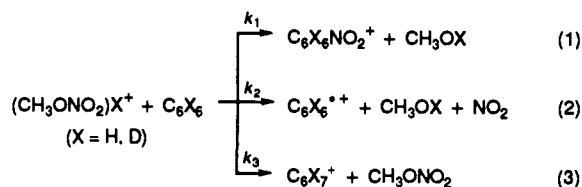

whose relative efficiency critically depends on the isomeric

Table 1. Relevant Thermochemical Data

species	H_f°	ref(s)
1	157.8	31
2	162.7	25, 31
<i>ipso</i> - $\text{C}_6\text{H}_6\text{NO}_2^+$	225	6
$\text{C}_6\text{H}_5\text{NO}_2\text{H}^+$	189	32

reaction	ΔH°	refs
$\text{CH}_3\text{ONO}_2^{*+} + \text{CH}_3\text{ONO}_2 \rightarrow 1 + \text{CH}_2\text{O} + \text{NO}_2$	-65	32
$i\text{-C}_3\text{H}_7^+ + \text{CH}_3\text{ONO}_2 \rightarrow 1 + \text{C}_3\text{H}_6$	+0.3	31
$i\text{-C}_3\text{H}_7^+ + \text{CH}_3\text{ONO}_2 \rightarrow 2 + \text{C}_3\text{H}_6$	+5.2	25, 31
$\text{H}_3^+ + \text{CH}_3\text{ONO}_2 \rightarrow 1 + \text{H}_2$	-77.4	31
$1 \rightarrow \text{CH}_3\text{OH} + \text{NO}_2^+$	23	31, 33
$1 + \text{C}_6\text{H}_6 \rightarrow \text{CH}_3\text{ONO}_2 + \text{C}_6\text{H}_7^+$	-0.3	31
$2 + \text{C}_6\text{H}_6 \rightarrow \text{CH}_3\text{ONO}_2 + \text{C}_6\text{H}_7^+$	-5.2	25, 31, 32
$1 + \text{C}_6\text{H}_6 \rightarrow \textit{ipso}\text{-C}_6\text{H}_6\text{NO}_2^+$	-0.8	6, 31, 32
$1 + \text{C}_6\text{H}_6 \rightarrow \text{C}_6\text{H}_5\text{NO}_2\text{H}^+$	-36.8	31, 32
$1 + \text{C}_6\text{H}_6 \rightarrow \text{C}_6\text{H}_6^{*+} + \text{NO}_2 + \text{CH}_3\text{OH}$	+15.3	31, 32

^a All values in kcal mol⁻¹, referred to 298 K. The heats of formation are taken from ref 32 except where otherwise noted. Values in italics are theoretically computed ones.

composition and the internal and the translational energy of the $(\text{CH}_3\text{ONO}_2)\text{X}^+$ ions.¹⁴ To compound matters, $\text{C}_6\text{X}_6^{*+}$ and C_6X_7^+ ions react with CH_3ONO_2 yielding $\text{C}_6\text{X}_6\text{NO}_2^+$, namely the same product formed from eq 1.^{14,27-30}

A rational design of the mass spectrometric experiments for the study of the reaction 1 must take into account the above problems. The multiplicity of the reagents and of the processes leading to $\text{C}_6\text{X}_6\text{NO}_2^+$ adduct(s) has suggested the choice of ICR spectrometry, which allows isolation of single ions by multiple resonance. The necessity of studying reaction 1 in the absence of methyl nitrate has required using an external ion source. Since, however, transferring the ions from the external source to the resonance cell imparts excess translation energy on them, collisional cooling by the pulsed-valve (PV) technique is required.

Finally, and most important, careful consideration has been given to the problem of producing a population of $(\text{CH}_3\text{ONO}_2)\text{-H}^+$ ions of well-defined isomeric composition, with the lowest possible excess of internal and translation energy.

Extensive preliminary tests have shown that thermal ions of structure 1 can be obtained in a state of high isomeric purity according to the following procedure:

Step 1. A mixed population of 1 and 2 is obtained by $\text{C}_3\text{H}_8/\text{CI}$ of methyl nitrate in the external ion source of a FT-ICR spectrometer via the process

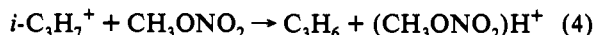

nearly thermoneutral for the formation of 1 (Table 1). Other major ions formed in the external source are NO_2^+ and $\text{CH}_3\text{O}(\text{NO}_2)_2^+$.

Step 2. All ions are transferred into the resonance cell, containing $\text{C}_6\text{H}_6/\text{CD}_3\text{OD}$ ($\text{C}_6\text{D}_6/\text{CH}_3^{18}\text{OH}$) mixtures of variable composition.

(26) Huffman, M. K.; Bursey, M. M. *Tetrahedron Lett.* 1971, 2533.
(27) Donbar, R. C.; Shen, G. A.; Olah, G. A. *J. Am. Chem. Soc.* 1972, 94, 6862.

(28) Ausloos, P.; Lias, S. G. *Int. J. Chem. Kinet.* 1978, 10, 657.
(29) Schmitt, R. J.; Buttrill, S. E., Jr.; Ross, D. S. *J. Am. Chem. Soc.* 1981, 103, 5263.

(30) Schmitt, R. J.; Buttrill, S. E., Jr.; Ross, D. S. *J. Am. Chem. Soc.* 1984, 106, 926.

(31) Recent ICR measurements^{31a} show that the PA of CH_3ONO_2 , 178 ± 2 kcal mol⁻¹, is very close to that of C_3H_6 , recently reevaluated to be 178.4 ± 0.6 kcal mol⁻¹.^{31b} Earlier ICR measurements gave a slightly lower value of PA (CH_3ONO_2), 176 kcal mol⁻¹ (cf. ref 6). (a) Ricci, A. *Org. Mass Spectrom.* 1994, 29, 55. (b) Szulejko, J. E.; McMahon, T. B. *J. Am. Chem. Soc.* 1993, 115, 7839.

(32) Lias, S. G.; Bartmess, J. E.; Liebman, J. F.; Holmes, J. L.; Levin, R. D.; Mallard, W. G. *J. Phys. Chem. Ref. Data* 1988, 17, Suppl. No. 1.

(33) (a) Bryant, G. B.; Jiang, Y.; Martin, M.; Grant, E. R. Manuscript in preparation quoted in ref 33b. (b) Sunderlin, L. S.; Squires, R. R. *Chem. Phys. Lett.* 1993, 212, 307.

(34) For a review, see: Kuck, D. *Mass Spectrom. Rev.* 1990, 9, 583.

Step 3. Following collisional thermalization by Ar, introduced via the PV, the $(\text{CH}_3\text{ONO}_2)\text{H}^+$ ions are isolated by selective-ejection techniques.

Step 4. The ions **1** are allowed to undergo the thermoneutral ligand exchange:

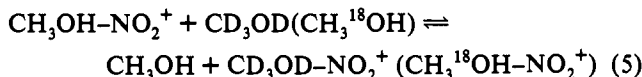

Step 5. All ions except $\text{CD}_3\text{OD}-\text{NO}_2^+(\text{CH}_3^{18}\text{OH}-\text{NO}_2^+)$ are ejected by "shots" of low intensity to prevent unintentional excitation of ions **1**, whose reaction with $\text{C}_6\text{H}_6(\text{C}_6\text{D}_6)$ is then studied over a suitable time interval.

The key feature of the method is that ions **2** cannot be formed via process 5, nor via any other conceivable reaction involving $(\text{CH}_3\text{ONO}_2)\text{H}^+$ ions (of whatever structure) with $\text{CD}_3\text{OD}(\text{CH}_3^{18}\text{OH})$, thus ensuring that the labeled ions formed can confidently be assigned structure **1**. A drawback is the relatively low intensity of the $\text{CD}_3\text{OD}-\text{NO}_2^+(\text{CH}_3^{18}\text{OH}-\text{NO}_2^+)$ signal, which however can be enhanced without appreciably impairing the isotopic purity (*vide infra*) by omitting thermalization by Ar that causes unavoidable losses of ions. Furthermore, one can utilize, as an additional route to labeling ions **1**, the NO_2^+ transfer process

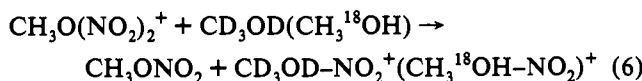

promoted by the $\text{CH}_3\text{O}(\text{NO}_2)_2^+$ ions formed in the external source. Obvious modifications are (i) using CD_3ONO_2 instead of CH_3ONO_2 to demonstrate that the methyl hydrons are not involved in isotopic exchanges and (ii) adding $\text{CH}_3^{18}\text{OH}$ or CD_3OD to promote formation of labeled ions **1** via processes 5 and 6 directly in the external ion source.

2. Results. Charge exchange (eq 2) is the major reaction channel of pure ions **1**, despite its significant endothermicity (Table 1), whereas nitration (eq 1) is appreciably slower and hydron transfer (eq 3) entirely absent, as illustrated in Figure 1a. Focusing attention on the nitration of C_6H_6 by $\text{CD}_3\text{OD}-\text{NO}_2^+$ ions, experiments performed at various $[\text{C}_6\text{H}_6]/[\text{CD}_3\text{OD}]$ ratios have allowed evaluation of its bimolecular rate constant $k_1 = 1.3 \pm 0.3 \times 10^{-10} \text{ cm}^3 \text{ s}^{-1} \text{ mol}^{-1}$ at 300 K, corresponding to a collision efficiency of the order of 10%. Within experimental errors, the k_1 value is unaffected by the isotopic composition of the reagents, e.g. it remains unchanged in passing from the $\text{CD}_3\text{OD}-\text{NO}_2^+/\text{C}_6\text{H}_6$ to the $\text{CH}_3\text{OH}-\text{NO}_2^+/\text{C}_6\text{D}_6$ pair. A distinctive feature of ions **1** is their inability to undergo hydron transfer (eq 3) to benzene, a slightly exothermic process (Table 1) which however would require considerable structural reorganization from the loose ion-molecule complex **1** to the tightly bounded MeONO_2 molecule.²⁵

Much work has been devoted to establishing the *initial* isotopic composition of the $\text{C}_6\text{X}_6\text{NO}_2^+$ ions from eq 1 to ascertain whether, and to what extent, they incorporate the hydron initially bound to the O atom of **1**. The problem has been addressed in two ways: (i) by examining the composition of $\text{C}_6\text{X}_6\text{NO}_2^+$ ions from $\text{C}_6\text{X}_6/\text{CX}_3\text{OX}$ mixtures of various composition after very short reaction times, and (ii) by isolating $\text{C}_6\text{X}_6\text{NO}_2^+$ ions and following the change of their isotopic composition (Figure 2). The two sets of experiments concur in showing that the *initial* composition of the nitrated adduct reflects that of benzene, i.e. $\text{C}_6\text{H}_6\text{NO}_2^+$ is initially formed from C_6H_6 and $\text{C}_6\text{D}_6\text{NO}_2^+$ from C_6D_6 . Subsequently, a fast hydron exchange occurs, e.g.

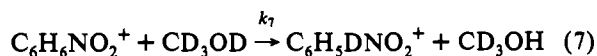

whose rate increases with the concentration of species containing exchangeable hydrons, such as CX_3OX , X_2O , etc., present in the

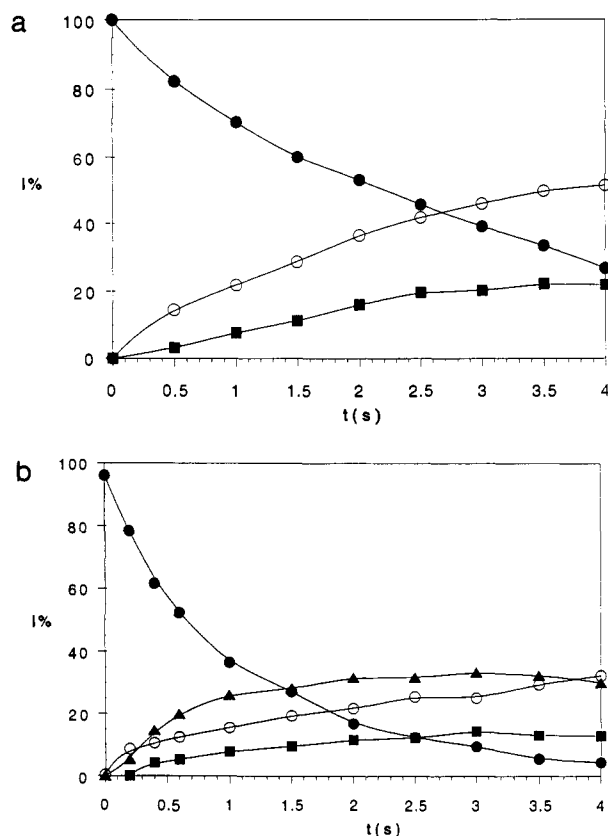

Figure 1. (a) Reaction with C_6D_6 of $\text{CH}_3\text{OH}-\text{NO}_2^+$ ions prepared, thermalized, and isolated as described in the text ($P(\text{C}_6\text{D}_6) = 2.0 \times 10^{-8}$ Torr; $P(\text{CH}_3\text{OH}) = 5 \times 10^{-9}$ Torr, $t = 25^\circ\text{C}$) and (b) reaction with C_6D_6 ($P = 4.7 \times 10^{-8}$ Torr, of a mixed population of $(\text{CH}_3\text{ONO}_2)\text{H}^+$ ions from the $\text{C}_3\text{H}_8/\text{Cl}$ of CH_3ONO_2 in the external ion source): (●) $(\text{CH}_3\text{ONO}_2)\text{H}^+$, (▲) C_6X_7^+ , (○) C_6X_6^+ , (■) $\text{C}_6\text{X}_6\text{NO}_2^+$.

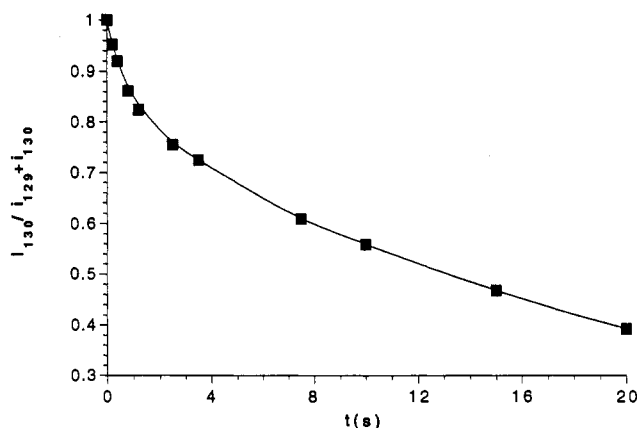

Figure 2. Isotopic exchange of $\text{C}_6\text{D}_6\text{NO}_2^+$ ions, $m/z = 130$, from the nitration of C_6D_6 by $\text{CH}_3\text{OH}-\text{NO}_2^+$ ions, with H_2O , yielding $\text{C}_6\text{D}_5\text{H}-\text{NO}_2^+$ ions, $m/z = 129$ ($P(\text{C}_6\text{D}_6) = 4.0 \times 10^{-8}$ Torr; $P(\text{H}_2\text{O}) \approx 4 \times 10^{-9}$ Torr).

system. By applying the steady-state approximation to the exchange kinetics at different CX_3OX concentrations we conclude that k_7 is comparable to the collision rate constant, as expected for hydron exchange between unhindered n-type bases. This suggests that the exchanging $\text{C}_6\text{X}_6\text{NO}_2^+$ ions have the O-protonated nitrobenzene structure, consistent with earlier evidence from CAD spectrometry, showing that ca. 10 μs after their formation the nitrated ions are structurally identical to model $\text{C}_6\text{X}_5\text{NO}_2\text{X}^+$ ions.⁶

The above results are mechanistically informative, allowing discrimination among the conceivable reactions sequences leading to formation of $\text{C}_6\text{X}_6\text{NO}_2^+$ ions and their subsequent isotopic

Chart 1

SEQUENCE A

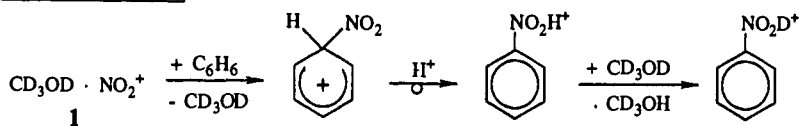

SEQUENCE B

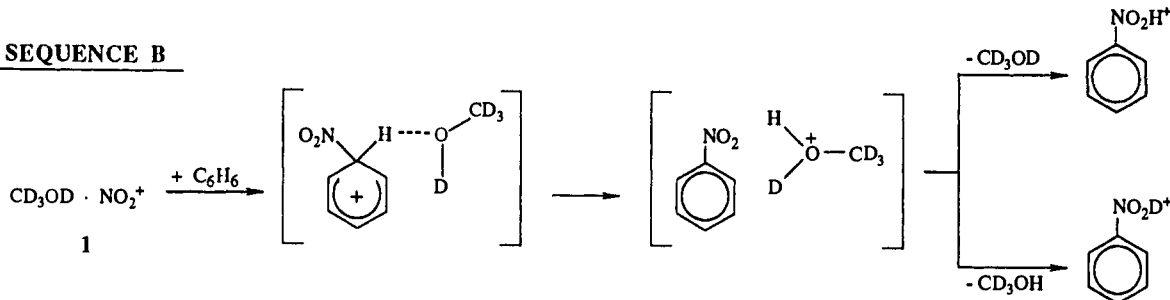

SEQUENCE C

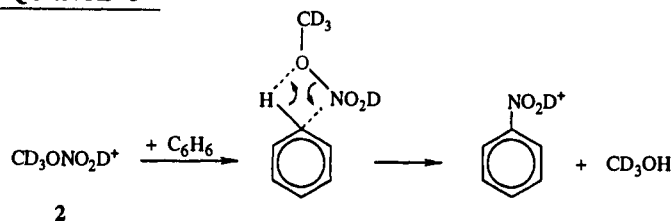

exchange (Chart 1). The ICR evidence is consistent with sequence A, excluding fast isotopic mixing within the ion-molecule complex formed by the arenium ion and the CX_3OX molecule formerly contained in ion 1 (sequence B). Incidentally, the ICR evidence denies the role of promoter 2 in the nitration process, since it would lead to the initial formation of $\text{C}_6\text{H}_5\text{DNO}_2^+$ or $\text{C}_6\text{D}_5\text{HNO}_2^+$ ions, according to the concerted mechanism^{6,19} of sequence C.

3. ICR Titration of Isomeric $(\text{CH}_3\text{ONO}_2)\text{H}^+$ Ions. The presence of 2 in $(\text{CX}_3\text{ONO}_2)\text{X}^+$ populations from reactions other than 5 and 6 is denoted by their reactivity toward benzene, which differs from that of pure 1 in two respects. First, in addition to nitration (eq 1) and charge exchange (eq 2), one observes hydron transfer (eq 3) yielding C_6X_7^+ ions, as apparent from the typical plot of Figure 1b. This is hardly surprising, since hydron transfer from 2 is more exothermic than from 1 (Table 1) and involves no extensive structural reorganization.

The second difference concerns the nitration rate. For each mixed $(\text{CX}_3\text{ONO}_2)\text{X}^+$ population an inverse correlation exists between the observed rate constant for hydron transfer, k_3^{obs} and for nitration, k_1^{obs} , the latter being invariably smaller than k_1 , typical of pure isomer 1. These observations can be rationalized assuming that nitration is promoted exclusively by 1 and hydron transfer by 2. It follows that the mole fraction x_1 in a given $(\text{CX}_3\text{ONO}_2)\text{X}^+$ population is given by the k_1^{obs}/k_1 ratio, which allows calculation of x_2 . By plotting the observed rate constants for hydron transfer, k_3^{obs} , vs the x_2 value obtained in this way, one can construct the plot of Figure 3, whose remarkable linearity speaks for the internal consistency of the model, although to make the procedure absolutely rigorous it would be necessary to find some way to prepare isomer 2 in the pure state. In the framework of the model, the rate constant k_3 for proton transfer from pure 2 to benzene can be obtained by extrapolating the plot to $x_2 = 100\%$. The value obtained in this way, $k_3 = 2.9 \times 10^{-10} \text{ cm}^3 \text{ s}^{-1} \text{ mol}^{-1}$, corresponds to a reasonable collisional efficiency, of the order of 25%.

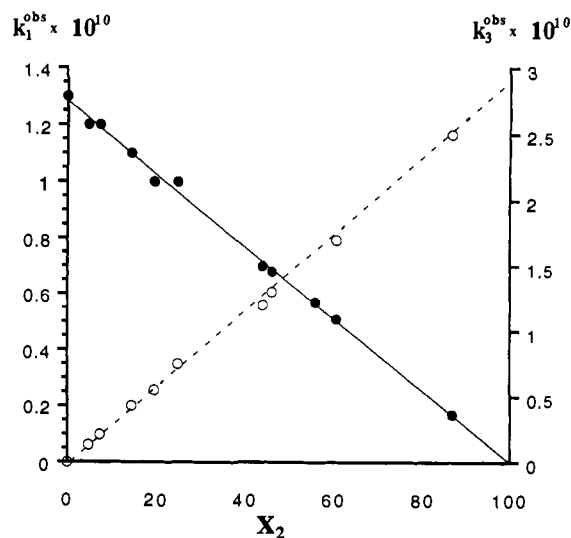

Figure 3. ICR "titration" of isomers 1 and 2 in a mixed $(\text{CX}_3\text{ONO}_2)\text{X}^+$ population, by reaction with C_6X_6 . Observed bimolecular rate constants for nitration, k_1^{obs} , and for protonation, k_3^{obs} , vs the mole fraction of promoter 2, see text.

Using the above "titration" procedure we have investigated the ways to obtain isomer 2 in high concentrations, if not in the pure state. The most effective procedure consists in operating the external CI source at low pressure ($< 5 \times 10^{-5}$ Torr), using a highly exothermic formation process, e.g. protonation of CX_3ONO_2 by $\text{CX}_3\text{ONO}_2^+\text{H}^+$, or other strong acids.²¹ In this way one obtains excited $(\text{CX}_3\text{ONO}_2)^+$ populations containing a significant fraction of 2, which can further be increased by allowing the excited ions to collide with Ar, introduced via the PV. It should be noted that whereas 1 is thermodynamically more stable, it is kinetically less stable than 2, whose dissociation into NO_2^+ and

Table 2. Isotopic Composition of *p*-*tert*-Butyltoluene from the Reaction of *t*-C₄H₉⁺ Ions with *p*-H-Toluene-*d*₇ in Isobutane at 760 Torr

system composition ^a (Torr)		temperature (°C)	H retention in <i>p</i> - <i>tert</i> -butyltoluene ^b (%)
toluene	base ^c		
0.94	0.97	42	31.6 ± 0.5
0.95	3.64	70	24.1 ± 0.4
0.80	0.82	100	48.1 ± 0.5
0.61	3.93	100	26.9 ± 0.4

^a All systems contained O₂ (10 Torr) as a radical scavenger. ^b Fraction of the H content of *p*-H toluene-*d*₇ retained in the product. ^c Triethylamine or pyridine.

CX₃OX, the energetically most accessible channel, requires prior conversion to **1**, characterized by a high barrier.²⁴ As a matter of fact, application of the above CAD technique to excited (CX₃-ONO₂)X⁺ ions from highly exothermic formation processes leads to a significant enrichment in promoter **2**, up to 80–90% according to our "titration" method.

B. Radiolytic Experiments. 1. Methods. One of the most typical facets of the reactivity of gaseous arenium ions is their tendency to undergo intramolecular hydron migration. Conversely, observation of H/D scrambling in the end products can be taken as a strong evidence for the intermediacy of arenium ions in their formation.

To apply this useful mechanistic probe we have utilized the radiolytic technique that, besides, allowing isolation of the neutral end products, and hence direct determination of their isotopic compositions,²⁰ has extensively been used in the study of aromatic nitration.^{6–9} We have focused attention on the nitration of toluene, which is known to give 59% *o*-, 7% *m*-, and 34% *p*-nitrotoluene.⁶ Two labeled substrates have been used, namely *p*-D-toluene-*h*₇ and *p*-H-toluene-*d*₇, whose preparation in a state of high (>99.9%) isotopic purity and accurate isotopic assay by GC/MS have required improved synthetic and analytical procedures. In a typical radiolytic experiment a mixture containing CX₄ as the bulk gas, CH₃ONO₂, toluene, a gaseous base, plus radicals and thermal-electrons scavengers, is irradiated with γ photons at a controlled temperature. (CH₃ONO₂)X⁺ ions, formed upon hydron transfer to methyl nitrate from C_nX₃⁺ ions (*n* = 1,2) from the ionization of CX₄, react with toluene yielding isomeric nitrotoluenes, whose isotopic composition is measured by GC/MS. The corrections required to take into account the incomplete labeling of the substrates, the ¹³C contributions, the isotopic effects in the fragmentation of the labeled ions, etc. have been made using as reference standards authentic samples of the corresponding pure nitrotoluene-*d*₇ and nitrotoluene-*h*₇ isomers. We have found it mechanistically informative to contrast the rate of intraannular H⁺ shifts in the arenium ion from the nitration of *p*-H-toluene-*d*₇ with that of H⁺ shifts in the arenium ions from the alkylation of the same substrate by gaseous *t*-C₄H₉⁺ ions, measured with the experimental approach described in previous reports.^{35–37} It was hoped that a quantitative comparison between the role and the extent of H⁺ migration in the two systems could provide useful information on the effects of the NO₂ group, the additional basic center present in the nitrated arenium ion, and a potential proton sink in view of its high relative basicity.

Consistent with earlier results we obtained only *m*- and *p*-*tert*-butyltoluene, whose proportions depend on the temperature and the concentration of gaseous bases, e.g. the para/meta ratio passes from 95:5 at 47 °C in the presence of 7.3 Torr of pyridine to 49:51 at 120 °C in the presence of 1.1 Torr of the base.³⁷

C. Results. We shall examine first *tert*-butylation, which provides a useful comparison term. The results of representative

(35) Cacace, F.; Giacomello, P. *J. Am. Chem. Soc.* **1973**, *95*, 5851.

(36) Cacace, F.; Ciranni, G. *J. Am. Chem. Soc.* **1986**, *108*, 887.

(37) Cacace, F.; Crestoni, M. E.; Fornarini, S. *J. Am. Chem. Soc.* **1992**, *114*, 6776.

experiments are illustrated in Table 2, which reports the composition of typical irradiated systems and the isotopic composition of *p*-*tert*-butyltoluene formed. The significant retention of H indicates that the gaseous arenium ions undergo extensive H shifts, whose extent increases at higher temperatures and lower bases concentrations. The results fit the model derived in an earlier study of the *tert*-butylation of *p*-D-toluene-*h*₇,³⁷ illustrated in a simplified form in Scheme 1 of Chart 2. Consistent with the model, the results of a systematic study performed at 42 °C using different concentrations of bases fit the linear trend predicted by the expression

$$\frac{[p\text{-}t\text{-}C_4H_9\text{-}C_7D_7]}{[p\text{-}t\text{-}C_4H_9\text{-}C_7HD_6]} = \frac{2k_b[B]}{k_s} + 1$$

where *k_b* and *k_s* are the rate constants for deprotonation and H shift, respectively. One can evaluate *k_s* by assuming that deprotonation by triethylamine, or pyridine, occurs at collisional frequency, which can be calculated,³⁸ and that the process has no appreciable kinetic isotope effect (KIE), which seems reasonable in view of the large PA difference between *tert*-butyltoluene and the above bases.³² In the temperature range investigated, from 42 to 100 °C, the *k_s* values fit a reasonably linear Arrhenius plot (Figure 4), characterized by log A = 13.5 ± 0.5 and *E*[‡] = 8.2 ± 0.4 kcal mol⁻¹. These results have an intrinsic interest, since they represent the first *direct* estimate of the activation parameters for thermal H shifts in a gaseous arenium ion and correlate very well with earlier results concerning D shifts in the same ion.³⁷ Comparison between the two sets of measurements shows, as expected, that the rate of intraannular shifts is higher for H than for D, e.g. at 320 K *k_s^H* = 9.2 ± 0.1 × 10⁷ s⁻¹ and *k_s^D* = 5.2 ± 0.2 × 10⁷ s⁻¹.

Passing to nitration, the results of representative experiments involving *p*-H-toluene-*d*₇ and *p*-D-toluene-*h*₇ reported in Table 3 display significant differences from those of Table 2. In the first place, retention of H (D) in the para-substituted product from *p*-H-toluene-*d*₇ (*p*-D-toluene-*h*₇) is much lower in nitration than in alkylation and does not significantly increase at higher temperatures, suggestive of a much lower rate of intraannular hydron migration. A striking feature is the apparently *higher* mobility of D than of H, reflected by the much *larger* (ca 3:1) retention of D than of H in *p*-nitrotoluenes. Furthermore, there is a small, yet measurable decrease of the H content in *o*- and *m*-nitrotoluenes from *p*-H-toluene-*d*₇, indicative of intraannular D shifts, e.g. whereas there is no corresponding decrease of the

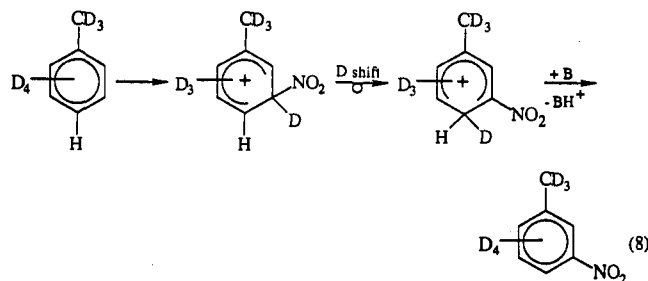

D content in *o*- and *m*-nitrotoluenes from *p*-D-toluene-*h*₇ These

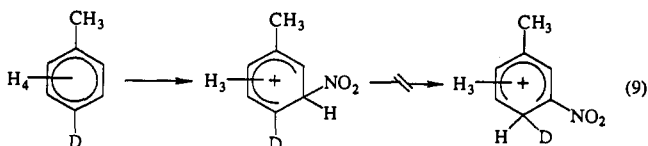

seemingly paradoxical results can be rationalized assuming that

Chart 2

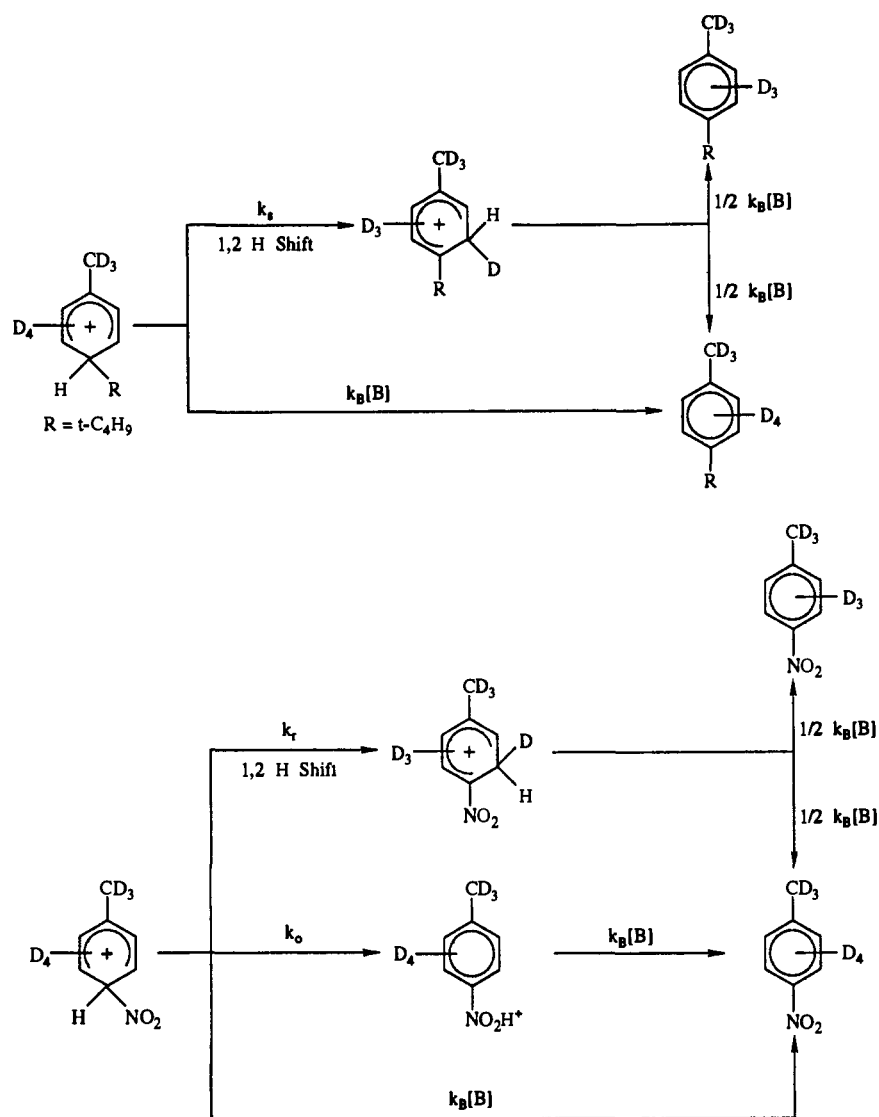

intraannular hydron shifts from the ipso position undergo competition by faster migration to the O atom of the nitro group, and that the latter process is characterized by a considerably larger primary KIE.

A model based on the above assumptions, illustrated in Scheme 2 (bottom half) of Chart 2, has been tested by measuring the isotopic composition of *p*-nitrotoluenes obtained from the nitration of *p*-*H*-toluene-*d*₇ in the presence of variable concentrations of a gaseous base B, triethylamine. By applying the steady-state approximation to Scheme 2 and assuming that deprotonation of the arenium and oxonium ions occurs at the same rate³⁹ without significant KIE's,⁴⁰ one obtains the expression

$$\frac{[p\text{-NO}_2\text{-C}_7\text{D}_7]}{[p\text{-NO}_2\text{-C}_7\text{HD}_6]} = 1 + \frac{2k_o}{k_r} + \frac{2k_b[\text{B}]}{k_r}$$

where k_o , k_r , and k_b denote the rate constants for H shift to the nitro group, H shift to other ring positions, and deprotonation by

(38) The thermal collision rate constants used have been calculated according to the ADO theory: (a) Bowers, M. T.; Su, T. In *Gas Phase Ion Chemistry*; Bowers, M. T., Ed.; Academic Press: New York, 1979. Upon request of a referee we have recalculated the collision rate constants using the more recent theory of Su and Chesnavich: Su, T.; Chesnavich, W. J. *J. Chem. Phys.* **1982**, *76*, 5183. The results are obviously the same for collisions involving benzene, whereas in the case of toluene the thermal collision rate constants from the ADO theory are somewhat smaller, e.g. for the (CH₃ONO₂)H⁺/C₇H₈ pair at 310 K the $k_{\text{coll}}/k_{\text{Langvin}}$ ratio from the ADO theory is 1.18 vs a ratio of 1.45 from the theory of Su and Chesnavich.

triethylamine, respectively. The experimental results obey the linear dependence of the products ratio on [B] required by the above equation, as shown in Figure 5. Making the usual assumption that $k_b = k_{\text{coll}}$,³⁹ one obtains $k_r \sim 1.6 \times 10^6 \text{ s}^{-1}$ and hence $k_o \sim 3.6 \times 10^7 \text{ s}^{-1}$ for H migration to the ring and to the nitro group, respectively, at 315 K.

The postulated hydron migration to the nitro group, independently supported by the mass spectrometric evidence presented in a previous section, accounts for the apparent inefficiency of 1,2-hydron shifts from the ipso carbon, which could hardly be rationalized on other grounds, since these shifts are generally slow only when the basicity of the ipso position is strongly enhanced by the substituent, as for example by the Si(CH₃)₃ group.⁴¹ This, however, is not the case of the nitro group, which on the contrary, according to 4-31G calculations, *depresses* the basicity of the ipso carbon with respect to unsubstituted ring positions.⁶ The same theoretical results point to the strong thermodynamic drive for hydron migration from the ipso position to the nitro group, whose basicity largely exceeds that of the ring, e.g. by some 30 kcal mol⁻¹ in the case of nitrobenzene.^{6,32} Competition between two alternative migration processes accounts also for the observed weak temperature dependence of the rate of intraannular hydron

(39) The strong thermodynamic drive for proton transfer from (C₇X₇-NO₂)H⁺ to (C₂H₅)₃N, $\Delta\text{PA} > 30 \text{ kcal mol}^{-1}$, ref 32, ensures that $k_b > 80\% k_{\text{coll}}$, ref 38. The efficiency can be lower if proton transfer is nearly thermoneutral, or hindered bases are involved, see: Bucker, H.; Grützner, H.-F. *Int. J. Mass Spectrom. Ion Processes* **1991**, *109*, 95.

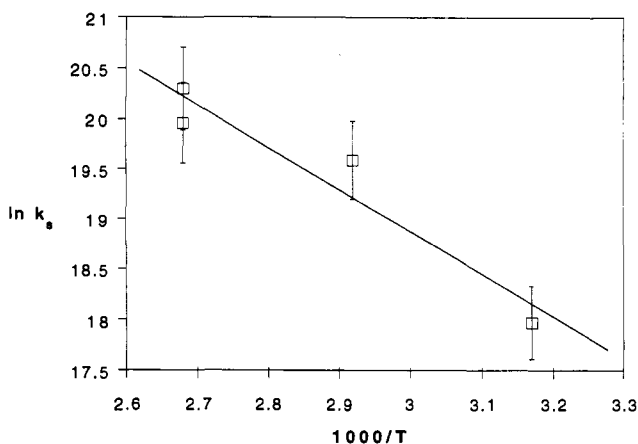

Figure 4. Arrhenius plot showing the temperature dependence of the k_a rate constant for *tert*-butylation of *p*-H-toluene- d_7 in isobutane at 760 Torr.

Table 3. Isotopic Composition of Nitrotoluenes from the Reaction of $(\text{CH}_3\text{ONO}_2)\text{H}^+$ Ions with Selectively Deuterated Toluenes in Methane at 760 Torr

system composition ^a (Torr)		temperature (°C)	H retention ^b in isomeric nitrotoluenes (%)		
toluene	base ^c		ortho	meta	para
0.30	0.31	42	97.3 ± 0.9	96.4 ± 0.9	1.6 ± 0.4
0.54	0.11	42	97.5 ± 0.5	97.5 ± 0.2	2.0 ± 0.3
0.55	0.20	42	97.7 ± 0.2	97.1 ± 0.2	1.7 ± 0.3
0.29	0.26	65	97.5 ± 0.3	97.1 ± 0.4	1.7 ± 0.3
0.36	0.33	80	97.4 ± 0.4	97.4 ± 0.4	1.9 ± 0.4

system composition ^a (Torr)		temperature (°C)	D Retention ^d in isomeric nitrotoluenes (%)		
toluene	base ^c		ortho	meta	para
0.40	0.29	37	100 ± 0.4	100 ± 0.4	4.3 ± 0.2
0.36	0.37	37	100 ± 0.4	100 ± 0.4	4.3 ± 0.2
0.19	0.19	60	100 ± 0.4	100 ± 0.4	4.5 ± 0.2
0.23	0.21	80	100 ± 0.4	100 ± 0.4	4.9 ± 0.2

^a All systems contained CH_3ONO_2 (10 Torr), O_2 (10 Torr), and SF_6 (5 Torr) as a thermal electron scavenger. ^b Fraction of the H content of *p*-H-toluene- d_7 retained in the product. ^c Triethylamine. ^d Fraction of the D content of *p*-D-toluene- h_7 retained in the product.

shifts, that otherwise would imply an unreasonably low activation energy. In fact, according to Scheme 2, the experimentally measurable temperature dependence actually reflects the *difference* between the activation energies of the two competing migration processes, whose individual values do not need to be unduly small.

A final point concerns the large primary KIE of the hydron transfer from the ipso ring carbon to the nitro group. Until recently, this feature of the proposed mechanism would have been regarded as unlikely, owing to the widespread notion that nonlinear transition states, like the one of the 1,3-shift of interest, are characterized by comparatively small KIE's. The perception of the problem has changed since a recent *ab initio* study has shown that transition states characterized by a large angular distortion lead instead to large $k_{\text{H}}/k_{\text{D}}$ ratios.⁴²

(40) The assumption is founded on the Bell criterion, see: Melander, L.; Saunders, W. H., Jr. *Reaction Rates of Isotopic Molecules*; Wiley: New York, 1980.

(41) Theoretical and experimental gas-phase studies demonstrate the high relative basicity of the ipso trimethylsilylated position, see: (a) Cacace, F.; Crestoni, M. E.; de Petris, G.; Fornarini, S.; Grandinetti, F. *Can. J. Chem.* **1988**, *66*, 3099. (b) Attinà, M.; Cacace, F.; Ricci, A. *J. Am. Chem. Soc.* **1991**, *113*, 5937. The scarce tendency of the proton to migrate from the ipso trimethylsilylated position is supported by unpublished radiolytic experiments showing that H retention in the para-substituted products from the reaction of *p*-H-toluene- d_7 with $(\text{CH}_3)_3\text{Y}^+$ ions is 1.4% (Y = Si) vs 30% (Y = C) under similar conditions at 42 °C.

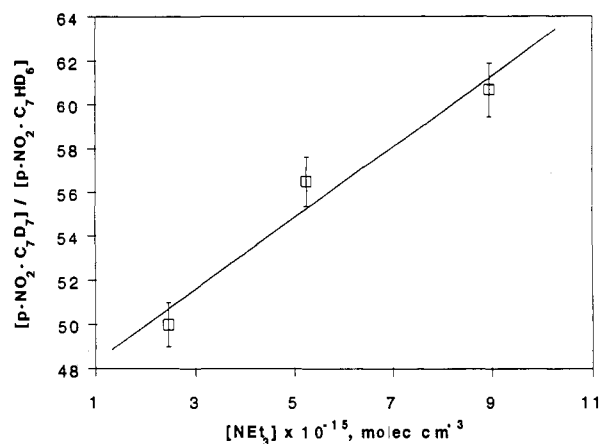

Figure 5. Linear dependence of the isotopic composition of *p*-nitrotoluene from the nitration of *p*-H-toluene- d_7 on the base concentration, [B].

Conclusions

The present mass spectrometric and radiolytic results concur in outlining a coherent picture of the reaction of protonated methyl nitrate with model arenes, whose salient features can be summarized as follows.

(i) With regard to the nitrating species, the present study elucidates a long-standing ambiguity, showing that *nitration is promoted exclusively by isomer 1*, whereas *2*, devoid of nitrating properties, behaves instead as a Brønsted acid.

(ii) *Nitration proceeds according to a classical mechanism involving formation of a Wheland intermediate*, which only in a subsequent stage isomerizes into the more stable O-protonated nitroarene.

It is interesting to compare the above conclusions with the previously available experimental and theoretical evidence.

The present results support those of a mass spectrometric and radiolytic study of the reaction of $(\text{CH}_3\text{ONO}_2)\text{H}^+$ ions with phenyl- and tolyltrimethylsilanes, whose nitration is accompanied by significant nitrodesilylation.⁹ In particular, the reported isolation of nitrotoluenes carrying the NO_2 group on ring positions other than the one formerly occupied by the $\text{Si}(\text{CH}_3)_3$ group, suggestive of intramolecular proton shifts in the nitrated arenium ions from phenyltrimethylsilanes, is in line with the present results concerning nitration of model arenes.

Comparison with the results of a recent *ab initio* study of aromatic nitration by isomeric $(\text{CH}_3\text{ONO}_2)\text{H}^+$ ions¹⁹ is of interest. With concern to point i, the theoretical results are not inconsistent with ours, since the barriers for nitration of benzene by **1** and **2** are computed to be 14.6 and 25.7 kcal mol⁻¹, respectively. The large barrier, and hence the inefficiency of the nitration process predicted for isomer **2** provide theoretical support to the experimentally observed predominance of competitive reaction channels, such as proton transfer from **2** to benzene. In this connection, it would be worthwhile to compute the energy profile of the latter process, not taken into account in the above cited theoretical study.¹⁹

As to the detailed course of nitration by **1**, the theoretical and experimental results concur in excluding direct formation of $\text{C}_6\text{H}_5\text{NO}_2$, or of $\text{C}_6\text{H}_5\text{NO}_2\text{H}^+$ ions via some kind of concerted mechanism, pointing to the role of the Wheland intermediate. However, a discrepancy does exist as to the lifetime of the latter, which according to the theoretical analysis¹⁹ is very short-lived, owing to the fast, spontaneous transfer of the ipso hydrogen to the methanol molecule formerly contained in the nitrating reagent, a contention not supported by the ICR and radiolytic evidence from this study.

Finally, the impact of gas-phase studies concerning $(\text{CH}_3\text{ONO}_2)\text{H}^+$ ions on the theory of aromatic nitration in solution is

considerably enhanced by the identification of the nitrating agent with isomer 1, in essence a nitronium ion solvated by a methanol molecule. Nitration by gaseous $\text{CH}_3\text{OH}-\text{NO}_2^+$ can be regarded as the addition of NO_2^+ to the arene studied in a microscopic volume of solution containing a single molecule of solvent and a large contribution to its activation energy can be traced to the desolvation barrier (DSB) that the NO_2^+ ions must overcome.^{19,43} In this perspective, gas-phase nitration by protonated methyl nitrate represents an extremely simplified, yet essentially correct model of aromatic nitration in condensed media, as suggested by the fundamental similarity of its kinetic and mechanistic features with those long established in solution.

Experimental Section

Materials. The gases and the other unlabeled chemicals were obtained from commercial sources, or prepared according to standard procedures. Methanol- d_4 (99.95 atom % D), used as such, or for the preparation of CD_3ONO_2 , benzene- d_6 (100.0 atom % D), and toluene- d_8 (100.0 atom % D) were obtained from Aldrich Chemical Co. The isotopic purity of the toluene- d_8 sample used for the preparation of *p*-H-toluene- d_7 was checked by GC/MS and found to correspond to 99.98 atom % D. Methane- d_4 (99.5 atom % D) and methanol- ^{18}O (95 atom % ^{18}O) were purchased from Cambridge Isotopes Laboratories and from Icon Services Inc. Preparation and purification of *p*-D-toluene- h_7 have previously been described.³⁷ A sample of *p*-H-toluene- d_7 was prepared from toluene- d_8 according to a procedure based on selective bromination at room temperature,⁴⁴ yielding *o*- and *p*-bromotoluene, without significant formation of the troublesome meta isomer, which cannot be removed from *p*-bromotoluene by preparative GC. Toluene- d_8 , dissolved in $\text{CH}_2\text{-Cl}_2$, was allowed to react with purified Br_2 in the dark for a period of 19 days. The bromotoluenes formed were analyzed by GC and GC/MS, using a model 5890A gas chromatograph equipped with a model 5970 mass selective detector from Hewlett-Packard Co., or a VG Micromass

TRIO-1 quadrupole GC/MS, on a $50\text{m} \times 0.2\text{mm} \times 0.5\ \mu\text{m}$ capillary column coated with a cross-linked methyl silicone phase (PONA column from Hewlett-Packard), operated in the 50–230 °C temperature range. The analysis showed that the *m*-brominated isomer content was <0.1%. The two major products, *o*- and *p*-bromotoluene, were separated by preparative GC using a $3\text{m} \times 6\text{mm}$ column packed with Carbowax 1500, 20% w/w on Chromosorb B, mounted in a ATC/f FRACTOVAP from C. Erba and operated at 130 °C. The purified *p*-bromotoluene- d_7 sample was converted into *p*-tolyl- d_7 -magnesium bromide, and the latter hydrolyzed to *p*-H-toluene- d_7 , which was separated and purified by preparative GC on the above columns and analyzed by GC/MS using the PONA column.

Radiolytic Experiments. The gaseous samples were prepared using standard vacuum procedures in sealed 250 mL Pyrex vessels and irradiated in a thermostatically controlled 220 Gammacell (Nuclear Canada Ltd.) at a total dose of 5×10^3 Gy at a dose rate of 2×10^4 Gy h^{-1} . The radiolytic products were extracted by freezing the vessel to 77 K and then washing the inner walls with methanol, with repeated freeze–thaw cycles. The nature, the yields, and the isotopic composition of the products were determined by GC/MS as described in the previous section concerning the analysis of the starting materials. The TRIO-1 quadrupole mass detector was operated in the EI mode for the analysis of *tert*-butylated and trimethylsilylated toluenes, and in the negative ion CH_4/CI mode for the analysis of the nitrated toluenes.

FT-ICR Spectrometry. The measurements were carried out using a Bruker-Spectrospin Apex TM 47e spectrometer, equipped with an external CI ion source, a pulsed valve, two separate inlets, and a XMASS TM data system. The total pressure in the resonance cell ranged from 3×10^{-8} to 8×10^{-8} Torr.

Warning! Methyl nitrate is a dangerous compounds prone to explosions when overheated or subjected to mechanical shocks. Inhalation of the vapors has adverse physiological effects.

Acknowledgment. Financial support from the Italian Ministero per l'Università e la Ricerca Scientifica e Tecnologica (MURST) and Consiglio Nazionale delle Ricerche (CNR) is gratefully acknowledged.

(43) Dewar, M. S. J.; Storch, D. M. *J. Chem. Soc., Perkin Trans. 2* 1989, 877.

(44) Conselvier, J. P. *Bull. Soc. Chim. Fr.* 1971, 1785; 1972, 762.